

mLCM

BC2002AI



Feature

1. Multi-interface : RS232/SPI/I2C
2. COB with metal frame
3. 5x7 dots with cursor
4. Built-in controller ST7066 or equivalent
5. 1/16 duty cycle
6. Backlight : LED EDGE/ARRAY
7. 5V single power supply
8. Contrast/Backlight adjustment by program

Mechanical Data

Item	Standard Value	Unit
Module Dimension	116.0 x 37.0	mm
Viewing Area	85.0 x 18.6	mm
Dot Size	0.60 x 0.65	mm
Character Size	3.2 x 5.55	mm

Pin Assignment

Pin	Symbol	Function
1	TX	RS-232 level output port.
2	RX	RS-232 level input port
3	VSS	Ground.
4	VDD	System power supply input.
5	SDA	I2C: Data Input/output for the I ² C SPI: Serial data Input
6	SCL	I2C: Clock Input for the I ² C SPI: Serial clock Input
7	SDO	SPI: Serial data Output
8	/CS	SPI: Chip select

Dimension

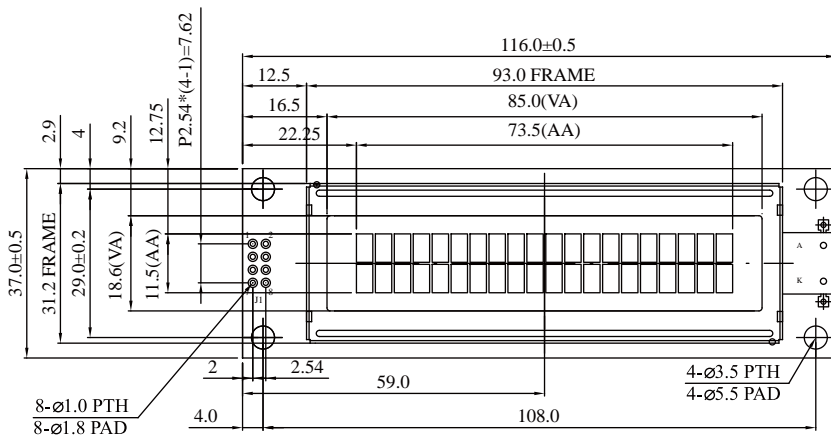

Electronic Characteristics

Item	Symbol	Condition	Value	Unit
Input Voltage	Vdd	Vdd = +5V	5.0(Typ.)	V
Supply Current with Backlight	Idd	Vdd = +5V	250(Max.)	mA

